

ELTEL

INDUSTRIES

ACTS-12K

AUTOMATIC CAPACITANCE & TAN DELTA TEST SET APPLICATION NOTES



**Eltel Industries is an ISO 9001 -2000
Registered Company.**

COPY RIGHT©ELTEL INDUSTRIES, 2006 All rights reserved. Printed in INDIA

008

Office : ELTEL Industries, 311, Embassy Centre,
Crescent Road, Bangalore - 560 001. INDIA
Tel : 91-80-22255467, 22205686, 22284298, 22284253
Fax : 91-08-22252733
E-mail : marketing@eltelindustries.com

Factory : ELTEL Industries, Plot # 39, KIADB Industrial Area,
Veerapura, Doddaballapur, Bangalore - 561 203. INDIA
Tel : 91-80-27630350, 27630366, 27630367, 27630368
Fax : 91-08-27630351
E-mail : eltel@vsnl.net

Website: <http://www.eltelindustries.com>

Table of Contents

1.	INTRODUCTION	1
2.	INSULATION TESTING OF TWO WINDING TRANSFORMERS	2
	2.1 Preparation for test	2
	2.2 Lead connections	3
	2.3 Conducting the Test.....	5
3.	INSULATION TESTING OF THREE WINDING TRANSFORMERS	10
	3.1 Preparation for test	10
	3.2 Lead connections	10
	3.3 Conducting the Test.....	11
4.	INSULATION TESTING OF BUSHINGS	16
	4.1 Insulation Testing of Bushing by the Capacitance Tap Method – UST.....	16
	4.1.1 Preparation for Test.....	16
	4.1.2 Lead Connections.....	17
	4.1.3 Conducting the Test.....	17
5.	INSULATION TESTING OF BULK OIL CIRCUIT BREAKER (O.C.B)	21
	5.1 Insulation Testing of Individual Bushings and De-Ion Grids (O.C.B. open).....	21
	5.1.1 Preparation for Test.....	21
	5.1.2 Lead Connections.....	21
	5.1.3 Conducting the Test.....	22
	5.2 Insulation Testing of Individual Bushings and Lift Rods Grids (O.C.B. closed)	26
	5.2.1 Preparation for Test.....	26
	5.2.2 Lead Connections.....	26
	5.2.3 Conducting the Test.....	26

6.	ANALYZING THE TEST RESULTS	27
6.1	Power Transformers.....	27
	1. Moisture	27
	2. Chemical contamination	27
	3. Core grounds	27
	4. On load tap changers	27
	5. Bushings	28
7.	INSULATION TESTING OF ROTATING MACHINERY	29
7.1	Introduction	29
7.2	Test voltage	29
7.3	Size of Capacitance and required equipment	30
7.4	Insulation testing of machines with simple windings	31
	7.4.1 Preparation for test	32
	7.4.2 Lead connections	32
	7.4.3 Conducting the Test	33
7.5	Insulation testing of machines with Parallel windings	38
	7.5.1 Preparation for test	39
	7.5.2 Lead connections	39
	7.5.3 Conducting the Test	39
7.6	Temperature corrections	41
7.7	Interpretation of results	41
	7.7.1 Power factor at low voltage ..	41
	7.7.2 Power factor tip-up	41
	7.7.3 Comparison between phases	42
8.	EXCITATION CURRENT TESTING OF TRANSFORMERS	43
8.1	Preparation for test	43
8.2	Lead Connections.....	44
8.3	Conducting the Test	44
9.	MAINTENANCE AND TROUBLE SHOOTONG	47

1 Chapter 1. INTRODUCTION

1. INTRODUCTION

The Eltel AUTOMATIC CAPACITANCE & DISSIPATION FACTOR TEST SET Model ACTS-12K is a self-contained Test Set, designed for field and shop testing of electrical insulation materials and systems at voltages of up to 12 kV. The Test Set is useful for evaluating the nature and quality of electrical insulation materials and systems, manufacturing processes, and for revealing contamination, fractures, punctures, and other defects, which may accompany the aging of insulation. Being equipped with two measuring leads, the test set can measure all the quantities necessary to complete an insulation power factor test report for two, three and multi-terminal electrical power equipment.

The Test Set is shielded and guarded and measures the Capacitance and Dissipation Factor of test specimens that may be grounded (GST) or ungrounded (UST). For easy transportability and simplicity of operation the Test Set is assembled as two units, namely:

- (a) Power Source (standard capacitor cum power supply box)
- (b) Measuring Bridge.

Optionally these two units can also be mounted on a 19" rack mount chassis and supplied.

READ THE ACTS-12K OPERATION AND INSTRUCTION MANUAL BEFORE PROCEEDING WITH INSTALLATION AND OPERATING THE INSTRUMENT.

Chapter 2. INSULATION TESTING OF TWO WINDING TRANSFORMERS

2. INSULATION TESTING OF TWO WINDING TRANSFORMERS

2.1 PREPARATION FOR TEST

MAKE CERTAIN THAT THE APPARATUS UNDER TEST AND THE ACTS-12K ARE DE-ENERGIZED BEFORE PROCEEDING WITH THE PREPARATION.

TESTS SHOULD NOT BE CARRIED OUT WHEN RAIN IS FALLING OR WHEN THERE IS CONDENSATION ON THE PORCELAIN.

TEST SHEET FOR TWO WINDING TRANSFORMERS IS INCLUDED IN THIS MANUAL.

1. Clean the transformer in the normal manner.
2. Remove risers and/ or all bus-bars and cables from all bushings.
3. Leave working grounds attached to the risers and/ or bus-bars and cables.
4. The porcelain surface of bushings should be clean and dry. Remove any dirt or oil with clean, dry rags.

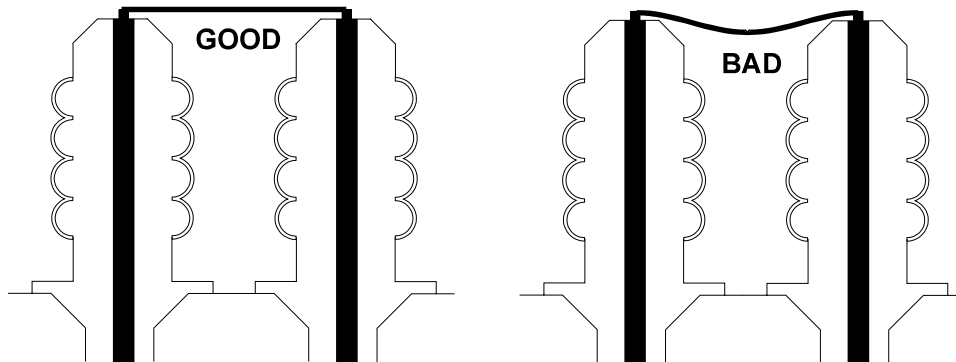

FIGURE 2-1 CORRECT METHOD OF SHORTING TRANSFORMER BUSHINGS

5. Short the high voltage bushings with a bare braided jumper. This is done to eliminate the inductance effect of the winding and create symmetrical balance of voltage gradient on the H and L sides of the transformer. The jumper should not be allowed to sag (refer to Figure 2-1).

6. Short the low voltage bushings as shown in Figure 2-2.

NOTE: The neutral, or star-point of a three-phase transformer winding should be connected to the other bushings of that winding by means of a shorting jumper.

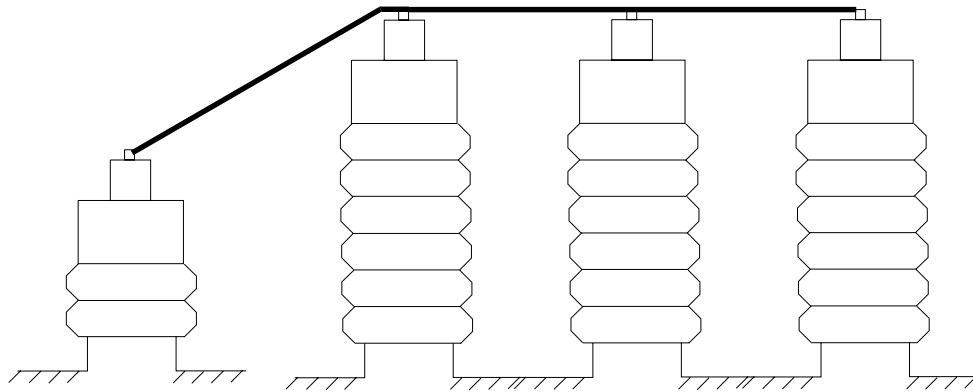

FIGURE 2-2 SHORTING THE LOW VOLTAGE BUSHING

7. Ensure that all neutrals are ungrounded.
8. Measure and record on the field sheet, the ambient temperature and relative humidity.
9. Record readings of transformer temperature gauge(s) - liquid and winding If present.
10. It is preferable that the transformer be tested after it has been allowed to cool to ambient temperature and that the ambient temperature be in the range of 10 to 40 degree Celcius.
11. If the transformer has an ON LOAD tap changer, it should be OFF NEUTRAL (on a full tap), otherwise thyrites in the tap changer may effect results.

2.2 LEAD CONNECTIONS (Refer to Figure 2-3)

1. Set up ACTS-12K as outlined in section 2.5 of the Operating and Instruction manual.
2. Interconnect the ACTS-12K protective ground terminals. Connect ACTS-12K Ground lead to a solid ground on the transformer under test. Ensure that any paint or oxide is removed, as this may cause erroneous readings.
3. Connect the ACTS-12K CxL blue lead to Low Voltage bushing of the transformer under test.

4. Connect the ACTS-12K High Voltage lead to the High Voltage bushing of transformer under test.

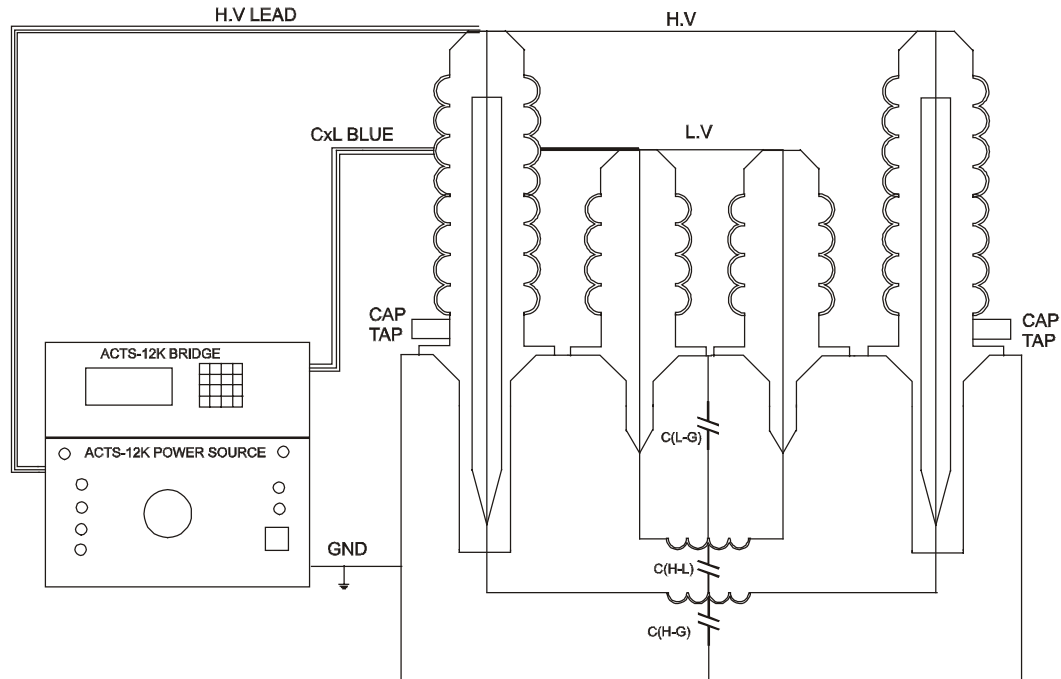

FIGURE 2-3. CONNECTIONS OF A TWO-WINDING TRANSFORMER

2.3 CONDUCTING THE TEST

The following is a step-by-step procedure for conducting a test on a specimen.

1. Prior to energising the Test Set, check entire circuit to make sure that all connections have been properly made and Test Set has been properly grounded.

Insure that specimen is de-energised and safe before making connections.

2. Keep POWER ON Switch at OFF position and set Voltage Control to zero.
3. Insert a shorting plug into " INTERLOCK" terminal and a Foot switch cable plug to the FOOT SWITCH terminal.
4. Connect Power supply to a suitable source of power.

5. Energise Test Set by switching on the POWER ON Switch. The red AC ON lamp should now be illuminated and the Bridge should display the following:



6. If on the Power source Open Ground LED comes ON, it indicates that the ground circuit in the power cable is open, or that there is a high resistance ground between the ground cable and power cable ground. The Test Set cannot be energised with high voltage with an open ground. Connect Proper ground to the Test set so that the Open Ground LED does not come ON.
7. Press any to continue on the Bridge. Then the following display will appear.

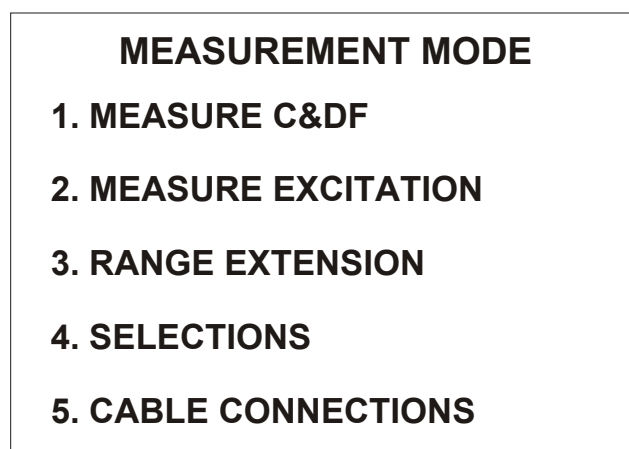

8. Press 1 to make Measurement of the Test specimen, then the following display should appear.

1. MEASURE C&DF		
<input type="checkbox"/>	1 UST Y	GST G 5 <input checked="" type="checkbox"/>
<input checked="" type="checkbox"/>	2 UST B	GST YG 6 <input type="checkbox"/>
<input type="checkbox"/>	3 UST YB	GST BG 7 <input checked="" type="checkbox"/>
<input type="checkbox"/>	4 GST YBG	
<input type="button" value="F1 - ViewRes"/> <input type="button" value="F2 - Check"/> <input type="button" value="Enter"/>		

9. For a Two Winding Transformer, Connected as shown in Figure2-3 select **2 UST B**, **5 GST G** and **7 GST BG** by depressing the corresponding number keys.

Where:

UST B is the measurement from High to Low windings with ground guarded.

GST G is the measurement from High to Ground with Low voltage windings guarded.

GST BG is the measurement from High to Low windings plus High to Ground. This is typically used to check the accuracy of the first two readings.

10. Make sure that the test area is clear. Close the Foot-Switch. Set Voltage Control to 'Zero' then depress ON Output Voltage button. The two red lamps at the top of the panel should now be illuminated. If these lamps do not come on, check to see if the Voltage Control is turned down to "0" and check if OFF Switch is re-set.

CAUTION!: THE HIGH VOLTAGE POWER SUPPLY IS NOW ON.

- 11.** Press enter on the bridge to get the following display.

```

1 MEASURE C&DF
Voltage   :           V
Current   :           mA

Enter to Continue
  
```

- 12.** Advance Voltage Control to Obtain desired test voltage.

Do NOT exceed the rated voltage of the transformer as this may damage the windings.

NOTE: Initially make a low voltage measurement, (like at 2kV for 10kV final measurement) for the safety of the Specimen as well as the instrument.

- 13.** When the test voltage is at the desired level, press Enter to commence measurements.
- 14.** The ACTS-12K will now proceed to perform the measurements and will display important portions of the measurement process, as they occur to give the operator an indication of what is happening.
- 15.** When the measurements are complete, the ACTS-12K will alert the operator via an audible alert signal, followed by a display similar to the following:

```

1 MEASURE C&DF

UST B
Voltage   : 10000 V
Current   : 3.000 mA
Capacitance : 1.008 nF
Power factor : 0.0005
Power     : 0.015 mW
Frequency  : 49.57 Hz
Interference : 0.207 %
                Final Result

F1 - Repeat  F2 - Check  F3 - Print
  
```

Release the Foot Switch interlock, to turn off the test voltage.

The test results can be viewed by using the up & down arrow keys or printed by utilising the F3-Print function on the menu.

- 16.** Move the High Voltage lead to Low voltage winding of the test transformer.

The operator who makes these connections MUST use the provided Hand switch interlock to ensure no high voltage can be energised while connections are being made.

- 17.** Move the CXL Blue lead to the High voltage winding of the transformer under test.
- 18.** Press the ESC key to go back to the Measurement mode menu and select Normal measurement by pressing 1.
- 19.** Tests, which were selected in step 9, are still enabled (boxes filled in). Disable the test not required, 2 **UST B**. This is done by depressing 2. The remaining two tests are required to complete the measurements of the transformer. The remaining tests are: 5 **GST G**, 7 **GST BG**.

Where: **GST G** is the measurement from Low voltage winding to Ground with High voltage winding guarded.

GST BG is the measurement from Low to High voltage winding plus Low voltage winding to Ground. This is typically used to check the accuracy of the GST G plus the UST B results.

- 20.** Repeat steps 10, 11, 12 and 13.
- 21.** When the measurements are complete, the ACTS-12K will alert the operator via an audible alert signal, followed by a display similar to the following:

1 MEASURE C&DF	
UST B	
Voltage	: 10000 V
Current	: 3.000 mA
Capacitance	: 1.008 nF
Power factor	: 0.0005
Power	: 0.015 mW
Frequency	: 49.57 Hz
Interference	: 0.207 %
Final Result	
<div style="display: flex; justify-content: space-around; margin-top: 10px;"> F1 - Repeat F2 - Check F3 - Print </div>	

Set Voltage Control to 'Zero', then depress HV OFF Switch, to turn off the test voltage. Release the Foot Switch interlock.

- 22.** Switch OFF the POWER ON on the Power Source before disconnecting the ACTS-12K from the apparatus under test.

Warning: Discharge test specimen with a safety ground ("hot stick") to ground all live parts, then solidly ground these parts with a ground bond. Always disconnect test cables from power equipment before attempting to disconnect them at the Test Set.

4. Connect the ACTS-12K CxL Blue lead to tertiary bushing of the transformer under test.
5. Connect the ACTS-12K High Voltage lead to the High Voltage bushing of transformer under test.

3.3 CONDUCTING THE TEST

The following is a step-by-step procedure for conducting a test on a specimen.

1. Prior to energising the Test Set, check entire circuit to make sure that all connections have been properly made and Test Set has been properly grounded.

Ensure that specimen is de-energised and safe before making connections.

2. Keep POWER ON Switch at OFF position and set Voltage Control to zero.
3. Insert a shorting plug into " INTERLOCK" terminal and a Foot switch cable plug to the FOOT SWITCH terminal.
4. Connect Power supply to a suitable source of power.
5. Energise Test Set by switching on the POWER ON Switch. The red AC ON lamp should now be illuminated and the Bridge should display the following:

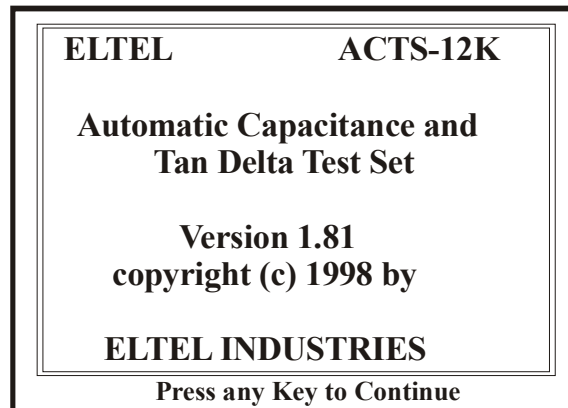

6. If on the Power source Open Ground LED comes ON, it indicates that the ground circuit in the power cable is open, or that there is a high resistance ground between the ground cable and power cable ground. The Test Set cannot be energised with high voltage with an open ground. Connect Proper ground to the Test set so that the Open Ground LED does not come ON.

7. Press any to continue on the Bridge. Then the following display will appear.

MEASUREMENT MODE

- 1. MEASURE C&DF**
- 2. MEASURE EXCITATION**
- 3. RANGE EXTENSION**
- 4. SELECTIONS**
- 5. CABLE CONNECTIONS**

8. Press 1 to make Measurement of the Test specimen, then the following display should appear.

1. MEASURE C&DF

<input checked="" type="checkbox"/>	1 UST Y	GST G	5	<input checked="" type="checkbox"/>
<input checked="" type="checkbox"/>	2 UST B	GST YG	6	<input type="checkbox"/>
<input type="checkbox"/>	3 UST YB	GST BG	7	<input type="checkbox"/>
<input checked="" type="checkbox"/>	4 GST YBG			

F1 - ViewRes

F2 - Check

Enter

9. For a Three Winding Transformer, Connected as shown in Figure3-1, select 1 **UST Y** 2 **UST B**, 4 **GST YBG** and 5 **GST G** by depressing the corresponding number keys.

Where:

UST Y is the measurement from High to Low windings with ground and tertiary guarded.

UST B is the measurement from High to Tertiary windings with ground and low windings guarded.

GST YBG is the measurement from High to Low plus High to Tertiary plus High to Ground. This measurement is used to check the total of the other three readings.

GST G is the measurement from High to Ground with the low and tertiary windings guarded.

10. Make sure that the test area is clear. Close the Foot-Switch. Set Voltage Control to `Zero` then depress ON Output Voltage button. The two red lamps at the top of the panel should now be illuminated. If these lamps do not come on, check to see if the Voltage Control is turned down to "O" and check if OFF Switch is re-set.

CAUTION!: THE HIGH VOLTAGE POWER SUPPLY IS NOW ON.

11. Press enter on the bridge to get the following display.

1 MEASURE C&DF	
Voltage	: V
Current	: mA
Enter to Continue	

12. Advance Voltage Control to Obtain desired test voltage.

Do NOT exceed the rated voltage of the transformer as this may damage the windings.

NOTE: Initially make a low voltage measurement, (like at 2KV for 10KV final measurement) for the safety of the Specimen as well as the instrument.

13. When the test voltage is at the desired level, press Enter to commence measurements.
14. The ACTS-12K will now proceed to perform the measurements and will display important portions of the measurement process, as they occur to give the operator an indication of what is happening.

15. When the measurements are complete, the ACTS-12K will alert the operator via an audible alert signal, followed by a display similar to the following:

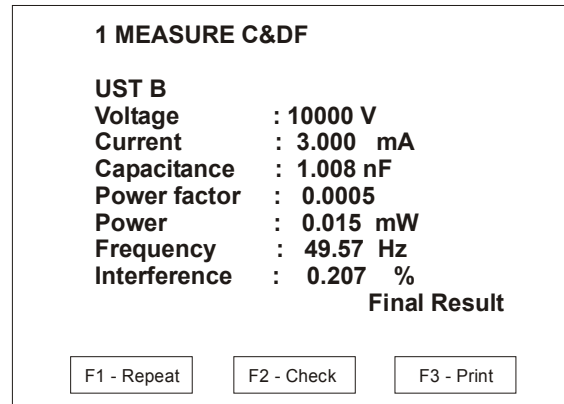

Set Voltage Control to 'Zero', then depress HV OFF Switch, to turn off the test voltage. Release the Foot Switch interlock.

The test results can be viewed by using the up & down arrow keys or printed by utilising the F3-Print function on the menu.

16. Move the High Voltage lead to Low voltage winding of the test transformer.

The operator who makes these connections MUST use the provided Hand switch interlock to ensure no high voltage can be energised while connections are being made.

17. Connect the CxL Yellow lead to the tertiary winding of the transformer under test.
18. Connect the CXL Blue lead to the High voltage winding of the transformer under test.
19. Press the ESC key to go back to the Measurement mode menu and select Normal measurement by pressing 1.
20. Select 1 **UST Y**, 5 **GST G** and 6 **GST YG** tests.

Where: **UST Y** is the measurement from Low to Tertiary windings with high winding and ground guarded.

GST G is the measurement from Low to Ground with the High and tertiary windings guarded.

GST YG is the measurement from Low to Tertiary plus Low to Ground. This is only a check of the first two readings.

Proceed to repeat steps of 10 to15 of this section.

21. Move the High Voltage lead to Tertiary voltage winding of the test transformer.

The operator who makes these connections MUST use the provided Hand switch interlock to ensure no high voltage can be energised while connections are being made.

22. Connect the CxL Yellow lead to the low voltage winding of the transformer under test.
23. Connect the CXL Blue lead to the High voltage winding of the transformer under test.
24. Press the ESC key to go back to the Measurement mode menu and select Normal measurement by pressing 1.
25. Select '5' **GST G** test.

Where: **GST G** is the measurement from Tertiary winding to Ground with the High and low windings guarded.

26. Proceed to repeat steps of 10 to15 of this section.

Measurements have now been obtained for all windings of the three winding transformer. They include:

High - Low, Low - Tertiary, Tertiary - Ground, High - Tertiary, Low - Ground, High - Ground.

4

Chapter 4. INSULATION TESTING OF BUSHINGS

4. INSULATION TESTING OF BUSHINGS

Bushings provide insulation to the entrance of high voltage conductors into an apparatus tank. The ACTS-12K will help the operator determine the condition of this insulation such that possible faults may be found and eliminated before extensive damage may occur. Although a bushing may be thought of as a somewhat simple device, its deterioration could have severe consequences.

Bushings handle high electrical stress in power devices and are therefore subject to greater incidences of failure.

4.1 INSULATION TESTING OF BUSHING BY THE CAPACITANCE TAP METHOD - UST

4.1.1 PREPARATION FOR TEST

MAKE CERTAIN THAT THE APPARATUS UNDER TEST AND THE ACTS-12K ARE DE-ENERGIZED BEFORE PROCEEDING WITH THE PREPARATION.

TESTS SHOULD NOT BE CARRIED OUT WHEN RAIN IS FALLING OR WHEN THERE IS CONDENSATION ON THE PORCELAIN. Preferably, tests should not be carried out when the relative humidity is in excess of 75%.

1. Clean the transformer in the normal manner.
2. Remove risers and/ or all bus-bars and cables from all bushings.
3. Leave working grounds attached to the risers and/ or bus-bars and cables.
4. The porcelain surface of bushings should be clean and dry. Remove any dirt or oil with clean, dry rags.
5. Short all the bushings of the same winding together, with a bare braided jumper. The jumper should not be allowed to sag (refer to Figure 4-1.).
6. Measure and record on the field sheet, type (Bushing Test), the ambient temperature and relative humidity.
7. Record readings of transformer temperature gauge(s) - liquid and winding, if present.

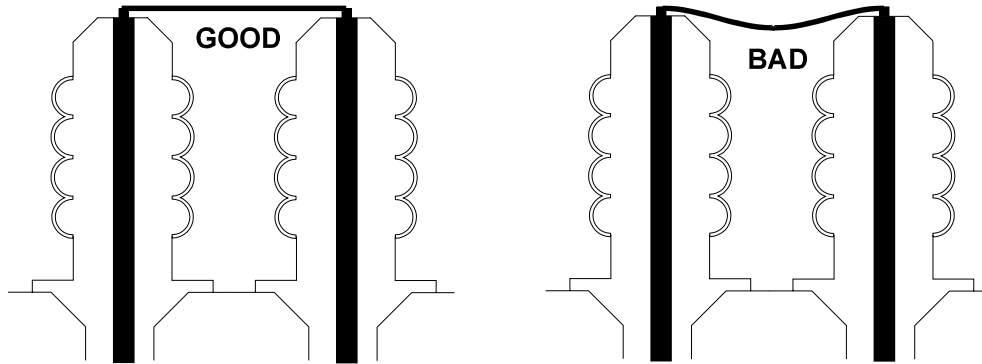
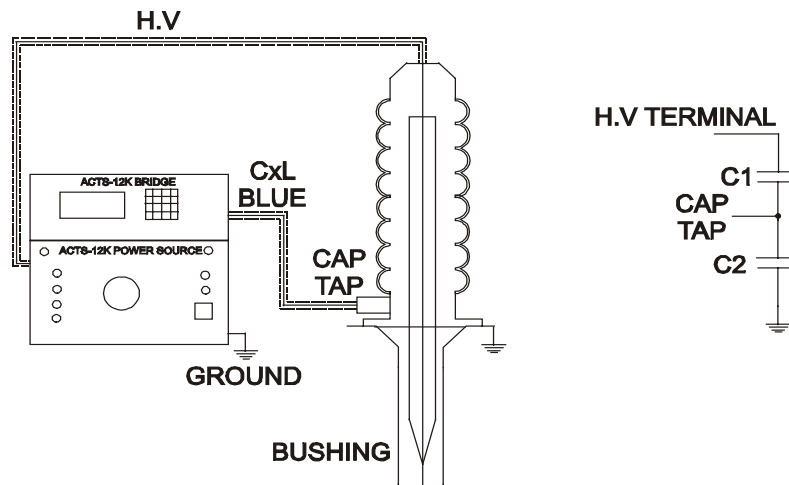

FIGURE4-1 CORRECT METHOD OF SHORTING TRANSFORMER BUSHINGS

8. Record the nameplate data of the bushings on the field test sheet, including the factory capacitance and power factor test data (if any). Where only one power factor value is given, assume this is to be for the C1 portion of the bushing (refer to Figure



4.2).

FIGURE 4-2 CONNECTION TO BUSHING BY THE CAPACITANCE TAP METHOD

4.1.2 LEAD CONNECTIONS

Refer to '2.2' of Application Notes section

4.1.3. CONDUCTING THE TEST

The following is a step-by-step procedure for conducting a test on a specimen.

1. Prior to energising the Test Set, check entire circuit to make sure that all connections have been properly made and Test Set has been properly grounded. Ensure that specimen is de-energised and safe before making connections.

2. Keep POWER ON Switch at OFF position and set Voltage Control to zero.
3. Insert a shorting plug into " INTERLOCK" terminal and a Foot switch cable plug to the FOOT SWITCH terminal.
4. Connect Power supply to a suitable source of power.
5. Energise Test Set by switching on the POWER ON Switch. The red AC ON lamp should now be illuminated and the Bridge should display the following:



6. If on the Power source Open Ground LED comes ON, it indicates that the ground circuit in the power cable is open, or that there is a high resistance ground between the ground cable and power cable ground. The Test Set cannot be energised with high voltage with an open ground. Connect Proper ground to the Test set so that the Open Ground LED does not come ON.
7. Press any to continue on the Bridge. Then the following display will appear.

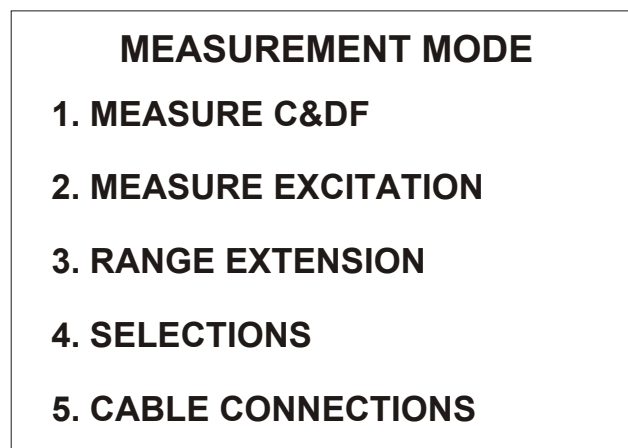

8. Press 1 to make Normal Measurement of the Test specimen, then the following display should appear.

1. MEASURE C&DF			
<input type="checkbox"/>	1 UST Y	GST G 5	<input type="checkbox"/>
<input checked="" type="checkbox"/>	2 UST B	GST YG 6	<input type="checkbox"/>
<input type="checkbox"/>	3 UST YB	GST BG 7	<input type="checkbox"/>
<input type="checkbox"/>	4 GST YBG		
<input type="button" value="F1 - ViewRes"/>		<input type="button" value="F2 - Check"/>	<input type="button" value="Enter"/>

9. For a high voltage bushing, connected as shown in FIGURE 2-2, select 2 **UST B** by depressing the corresponding number key.

Where:

UST B is the measurement from High voltage terminal to the Capacitance tap, C1 to Low windings with ground guarded.

10. Make sure that the test area is clear. Close the Foot-Switch. Set Voltage Control to 'Zero' then depress ON Output Voltage button. The two red lamps at the top of the panel should now be illuminated. If these lamps do not come on, check to see if the Voltage Control is turned down to "0" and check if OFF Switch is re-set.

CAUTION!: THE HIGH VOLTAGE POWER SUPPLY IS NOW ON.

11. Press enter on the bridge to get the following display.

1 MEASURE C&DF	
Voltage	: V
Current	: mA
Enter to Continue	

12. Advance Voltage Control to Obtain desired test voltage.

Do NOT exceed the rated voltage of the transformer as this may damage the windings.

NOTE: Initially make a low voltage measurement, (like at 2kV for 10kV final measurement) for the safety of the Specimen as well as the instrument.

13. When the test voltage is at the desired level, press Enter to commence measurements.
14. The ACTS-12K will now proceed to perform the measurements and will display important portions of the measurement process, as they occur to give the operator an indication of what is happening.
15. When the measurements are complete, the ACTS-12K will alert the operator via an audible alert signal, followed by a display similar to the following:

1 MEASURE C&DF

UST B

Voltage	: 10000 V
Current	: 3.000 mA
Capacitance	: 1.008 nF
Power factor	: 0.0005
Power	: 0.015 mW
Frequency	: 49.57 Hz
Interference	: 0.207 %

Final Result

F1 - RepeatF2 - CheckF3 - Print

Release the Foot Switch interlock, to turn off the test voltage.

The test results can be viewed by using the up & down arrow keys or printed by utilising the F3-Print function on the menu.

5

Chapter 5. INSULATION TESTING OF BULK OIL CIRCUIT BREAKER

5. INSULATION TESTING OF BULK OIL CIRCUIT BREAKER (O.C.B)

5.1 INSULATION TESTING OF INDIVIDUAL BUSHINGS AND DE-ION GRIDS (O.C.B OPEN)

5.1.1 PREPARATION FOR TEST

MAKE CERTAIN THAT THE APPARATUS UNDER TEST AND THE ACTS-12K ARE DE-ENERGIZED BEFORE PROCEEDING WITH THE PREPARATION.

TESTS SHOULD NOT BE CARRIED OUT WHEN RAIN IS FALLING OR WHEN THERE IS CONDENSATION ON THE PORCELAIN. Preferably, tests should not be carried out when the relative humidity is in excess of 75%.

1. Clean the transformer in the normal manner.
2. Remove risers and/ or all bus-bars and cables from all bushings.
3. Leave working grounds attached to the risers and/ or bus-bars and cables.
4. The porcelain surface of bushings should be clean and dry. Remove any dirt or oil with clean, dry rags.
5. Measure and record on the field sheet, the environmental conditions on test sheet, type (Bulk Oil Circuit Breaker).
6. Record the nameplate data of the circuit breaker on the field test sheet, including the factory capacitance and power factor test data (if any).

5.1.2 LEAD CONNECTIONS (Refer to Figure 5-2.)

1. Set up ACTS-12K as outlined in section 2.5 of the Operating and Instruction manual.
2. Interconnect the ACTS-12K protective ground terminals. Connect ACTS-12K Ground lead to a solid ground on the transformer under test. Ensure that any paint or oxide is removed, as this may cause erroneous readings.
3. The breaker should be OPEN.

4. Connect the ACTS-12K High Voltage lead to the High Voltage bushing in position 1 (refer to Figure 5.1). Keep the rest of the lead clear of the porcelain.
5. The ACTS-12K CxL Blue lead is not needed for this test and therefore may be left disconnected from the instrument.

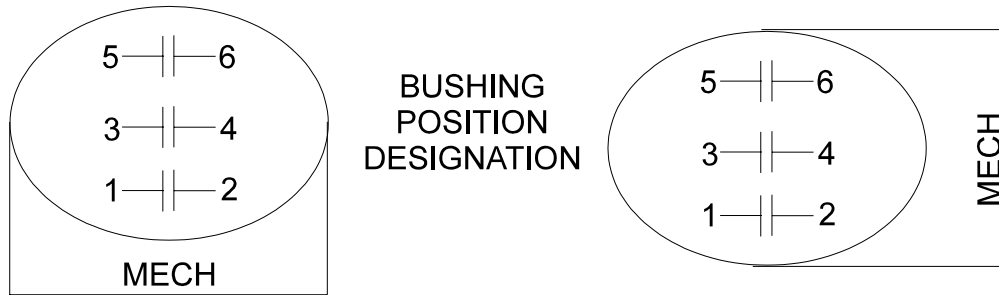

FIGURE 5-1 O.C.B. BUSHING POSITION DESIGNATIONS

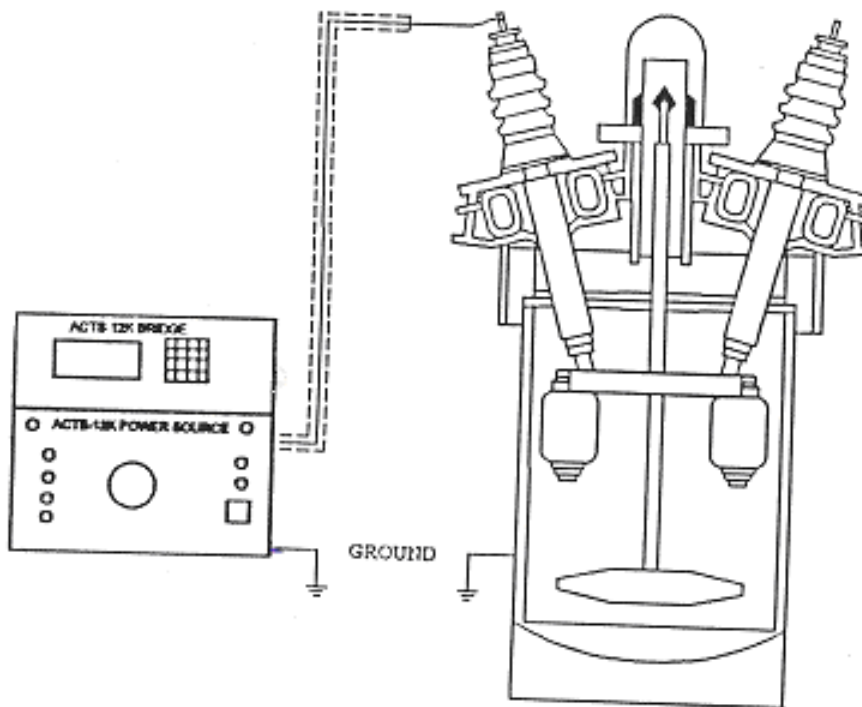

FIGURE 5-2 CONNECTION TO AN OIL CIRCUIT BREAKER (O.B.C OPEN)

5.1.3. CONDUCTING THE TEST

The following is a step-by-step procedure for conducting a test on a specimen.

1. Prior to energising the Test Set, check entire circuit to make sure that all connections have been properly made and Test Set has been properly grounded.

- Insure that specimen is de-energised and safe before making connections.
2. Keep POWER ON Switch at OFF position and set Voltage Control to zero.
 3. Insert a shorting plug into " INTERLOCK" terminal and a Foot switch cable plug to the FOOT SWITCH terminal.
 4. Connect Power supply to a suitable source of power.

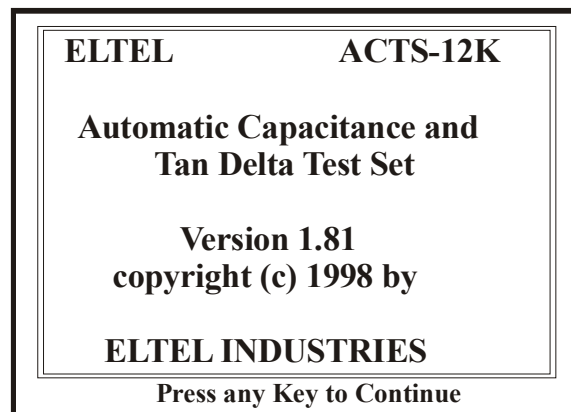

5. Energise Test Set by switching on the POWER ON Switch. The red AC ON lamp should now be illuminated and the Bridge should display the following:
6. If on the Power source Open Ground LED comes ON, it indicates that the ground circuit in the power cable is open, or that there is a high resistance ground between the ground cable and power cable ground. The Test Set cannot be energised with high voltage with an open ground. Connect Proper ground to the Test set so that the Open Ground LED does not come ON.
7. Press any to continue on the Bridge. Then the following display will appear.

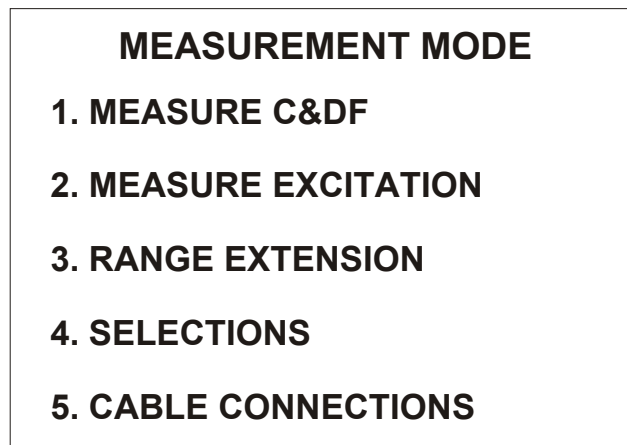

8. Press 1 to make measurement of the Test specimen, then the following display should appear.

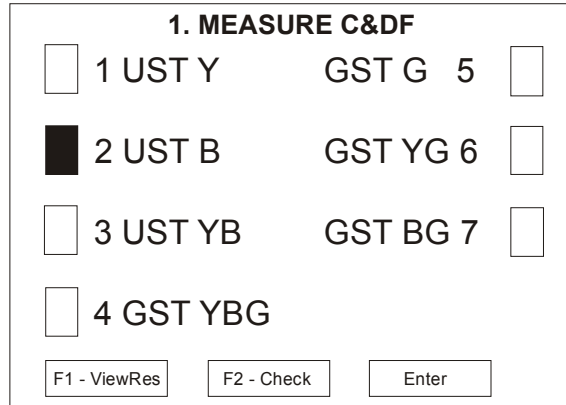

9. For a high voltage bushing, connected as shown in FIGURE 5-2, select 2 **UST B** by depressing the corresponding number key.

Where:

UST B is the measurement from High voltage terminal to the Capacitance tap, C1 to Low windings with ground guarded.

10. Make sure that the test area is clear. Close the Foot-Switch. Set Voltage Control to `Zero' then depress ON Output Voltage button. The two red lamps at the top of the panel should now be illuminated. If these lamps do not come on, check to see if the Voltage Control is turned down to "O" and check if OFF Switch is re-set.

CAUTION!: THE HIGH VOLTAGE POWER SUPPLY IS NOW ON.

11. Press enter on the bridge to get the following display.

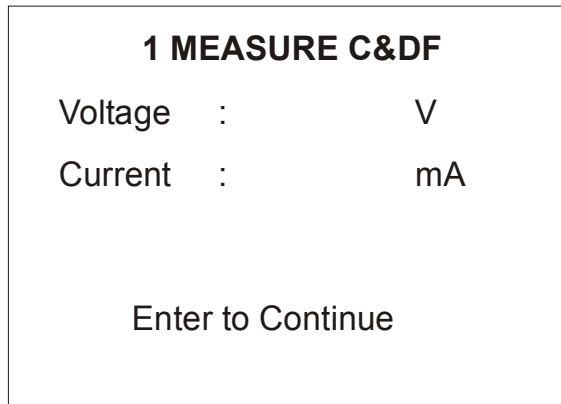

12. Advance Voltage Control to Obtain desired test voltage.

Do NOT exceed the rated voltage of the transformer as this may damage the windings.

NOTE: Initially make a low voltage measurement, (like at 2kV for 10kV final measurement) for the safety of the Specimen as well as the instrument.

13. When the test voltage is at the desired level, press Enter to commence measurements.
14. The ACTS-12K will now proceed to perform the measurements and will display important portions of the measurement process as they occur to give the operator an indication of what is happening.
15. When the measurements are complete, the ACTS-12K will alert the operator via an audible alert signal, followed by a display similar to the following:

1 MEASURE C&DF	
UST B	
Voltage	: 10000 V
Current	: 3.000 mA
Capacitance	: 1.008 nF
Power factor	: 0.0005
Power	: 0.015 mW
Frequency	: 49.57 Hz
Interference	: 0.207 %
Final Result	
<input type="button" value="F1 - Repeat"/> <input type="button" value="F2 - Check"/> <input type="button" value="F3 - Print"/>	

Set Voltage Control to 'Zero', then depress HV OFF Switch, to turn off the test voltage. Release the Foot Switch interlock.

The test results can be viewed by using the up & down arrow keys or printed by utilising the F3-Print function on the menu.

NOTE: If the measurements appear to be greatly influenced by Interference i.e., if the interference percentage is more than 25% on the display of the final result, repeat the above measurements using Multiple or Multiple + In Suppression measurement modes. This should improve the results.

16. Repeat sections 5.1.2. and 5.1.3. on each bushing in turn (Positions 2-6, on Fig 5-1.)

5.2 INSULATION TESTING OF INDIVIDUAL BUSHINGS AND LIFT RODS (O.C.B CLOSED)

5.2.1 PREPARATION FOR TEST

Follow the instructions outlined in section 5.1.1.

5.2.2 LEAD CONNECTIONS (Refer to Figure 5-2.)

1. Set up ACTS-12K as outlined in section 2.5 of the Operating and Instruction manual.
2. Interconnect the ACTS-12K protective ground terminals. Connect ACTS-12K Ground lead to a solid ground on the transformer under test. Ensure that any paint or oxide is removed, as this may cause erroneous readings.
3. The breaker should be CLOSED.
4. Connect the ACTS-12K High Voltage lead to the High Voltage bushing in position 1 or 2 (refer to Figure 5.1). Note that these two bushings should be shorted together. Keep the rest of the lead clear of the porcelain.
5. The ACTS-12K CxL Blue lead is not needed for this test and therefore may be left disconnected from the instrument.

5.2.3. CONDUCTING THE TEST

Follow the instructions outlined in section 5.1.3.

Note that testing on Circuit Breakers should be supplemented by separate tests on the bushings (refer to section 5.0)



Chapter 6. ANALYZING THE TEST RESULTS

6. ANALYZING THE TEST RESULTS

6.1 POWER TRANSFORMERS

The results from tests on two winding transformers, three winding transformers, regulators and reactors provide valuable information regarding the general condition of the ground and interwinding insulation of transformers. The results also provide valuable information concerning the dryness of the transformer, and are helpful in detecting undesirable operating conditions and failure hazards resulting from :

1. MOISTURE

- Moisture can be absorbed by the paper insulation.
- Free water in the liquid state, which is lying in pools on the insulation surface.

Both the above conditions may be detected by the dissipation factor test. However, free water in the form of ice will not be detected.

2. CHEMICAL CONTAMINATION

Reaction between acids in the transformer oil and residue from materials used in treating the core iron may result in the production of sodium soaps. These high loss materials result in :

- high dissipation factor on winding measurements.
- high dissipation factor on testing oil samples.

While increased winding dissipation factor due to chemical contaminants in the oil may not result in any failure hazard, it can mask more serious defects.

3. CORE GROUNDS

In two winding power transformers the low voltage winding is usually next to the core. If the dissipation factor of the low voltage winding to ground insulation appears to increase from one test to the next and the capacitance appears to decrease, then it is possible that the core ground circuit is discontinuous.

4. ON LOAD TAP CHANGERS

If one performs dissipation factor tests with the on load tap changer on neutral high values of dissipation factor may result. When on the neutral position, the regulating winding is often tied in only through a resistor. If the ohmic value of this resistor at low

voltage is high then the apparent dissipation factor of the regulating winding will increase. Therefore it is good practice to always move an on load tap changer off the neutral position before dissipation factor measurements are made.

5. BUSHINGS

The lower the capacitance to ground of a given winding the greater will be the effect of the condition of the associated bushings on the overall winding dissipation factor.

- i. Modern transformers insulated with oil/paper materials (no varnish impregnation of coils) have dissipation factors of less than 1.0% and often less than 0.5% at 20°C.
- ii. Transformers built prior to 1939 often have varnished coils and other high loss insulating materials are employed. Consequently dissipation factors as high as 2 or 3% at 20°C are not uncommon for these transformers.

In each case the most important criterion is the comparison with previous test data on the same transformer and other similar transformers. Remember also that when testing power transformers include the transformer oil and the bushing in the measurement. These should always be tested separately.

The following percentages are to be used in evaluating the results on ASKAREL and OIL-FILLED (free-breathing and conservator types) transformers at 20° C:

GOOD	-	Up to 2.0 % power factor.
Investigative	-	2.01 to 4.0 % power factor.
Bad	-	4.01 % power factor and above.

The following percentages are to be used in evaluating the results on OIL- FILLED (SEALED and GAS-BLANKETED type) transformers at 20° C.

GOOD	-	Up to 1.5 % power factor.
Investigative	-	1.51 to 3.0 % power factor.
Bad	-	3.01 % power factor and above.

For oil-filled reactors test and evaluation as on oil-filled power transformers should be used.

The following values are to be used in evaluating the results on regulators at 20° C.

GOOD	-	Up to 2.0 % power factor.
Investigative	-	2.01 to 4.0 % power factor.
Bad	-	4.01 % power factor and above.

7 Chapter 7. INSULATION TESTING OF ROTATING MACHINERY

7. INSULATION TESTING OF ROTATING MACHINERY

7.1 INTRODUCTION

This guide is especially prepared for testing the quality of insulation of motors, generators and synchronous condensers. Although prepared especially for large three phase machines, the information is also applicable to two phase, or even to smaller single phase machines.

The ACTS-12K is an dissipation factor test set, providing measurement of the capacitance and power factor, or dissipation factor of the **ground wall and interphase insulation** used within the machine. The dissipation factor test does not provide information on the turn-to-turn insulation of coils or windings. The turn-to-turn insulation must be evaluated using surge techniques.

7.2 TEST VOLTAGE

The maximum test voltage for a rotating machine depends on the age of the machine and the maintenance practices of the utility. Insulation of **new machines** is typically tested for dissipation factor up to the high pot voltage, which is twice the line-to-line rating. Dissipation factor measurements on such machine insulation would be made at least at four test voltages, namely $2xV_{rated}$, $1.5xV_{rated}$, V_{rated} and $0.5xV_{rated}$. In many cases the dissipation factor would be measured at many more voltage test points, typically every 5 or 10% of the machine voltage rating. The difference between the dissipation factor at rated voltage and that at half the rated voltage is referred to as TIP-UP.

For used machines, the test voltage seldom exceeds the voltage rating, and in many instances is limited to the phase voltage of the machine. Similarly as for new equipment, a minimum of 4 test points are taken.

In summary, the following are the typical test points :

New Equipment : Max. Test voltage = $2xV_{rated}$

Used Equipment : Max. Test voltage = V_{rated} or $0.6xV_{rated}$

The number of test points should not be fewer than 4. When doing the 4 test points, they should be 100, 50, 25 and 12% of the maximum test voltage. When doing tests at 10 to 20% voltages, these should be evenly distributed at every 5 or 10% of the maximum test voltage.

7.3 SIZE OF CAPACITANCE AND THE REQUIRED EQUIPMENT

The maximum capacitance of the specimen under test determines whether the ACTS-12K can be used directly for the test or if additional accessories are required. FIGURE 9-1. Shows the maximum capacitance that can be measured at various test voltages, using the ACTS-12K.

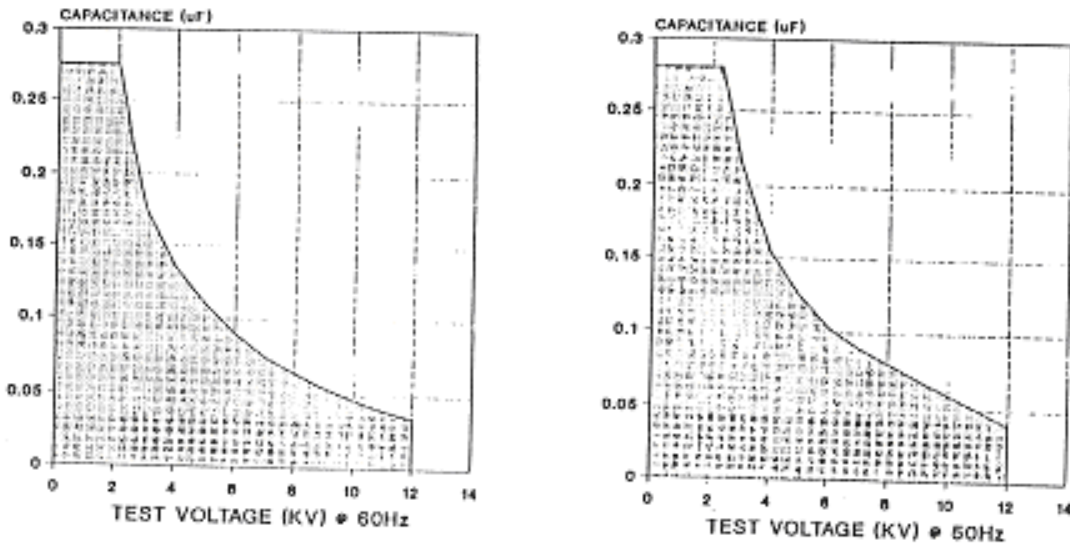

FIGURE 7-1 POWER SUPPLY CAPABILITY OF THE ACTS-12K

If the value of the capacitance of the specimen under test falls outside of these curves, there is one possible solution. The solution involves absorbing some of the capacitive charging current and therefore increase the capability of the ACTS-12K. **THE PROCEDURE FOR USING THE FOLLOWING ITEM IS COVERED IN ITS OPERATING AND INSTRUCTION MANUAL.**

High voltage compensating Inductors

These inductors are connected in parallel with the high voltage power supply of the ACTS-12K, and will increase the test capability of the ACTS-12K, as shown in FIGURES 7-2 and 7-3. Please note that these inductors can be used only in conditions where the maximum capacitance is less than 0.26uF, but the power supply is not capable of delivering the charging current.

7.4 INSULATION TESTING OF MACHINES WITH SIMPLE WINDINGS

The insulation within a machine consists primarily of two parts, the phase to ground insulation and the phase to phase insulation. This is shown diagrammatically in FIGURE 7-4.

In normal situation the machine windings can be separated from each other to allow the measurement of the six components identified in Figure 1. In cases where the windings cannot be separated, only one capacitance, all phases to ground, can be measured and assessed. This single measurement is usually of limited use.

It is assumed that the machine stator winding has its star point, or its delta connection, disconnected to provide three separate windings. The diagram of capacitances to be measured is shown in FIGURE 7-2. To measure all the required quantities, three separate connections and a minimum of 6, but preferably 9 measurements should be taken. To double check every one of the measurements, it may be desirable to make a full set of 21 readings.

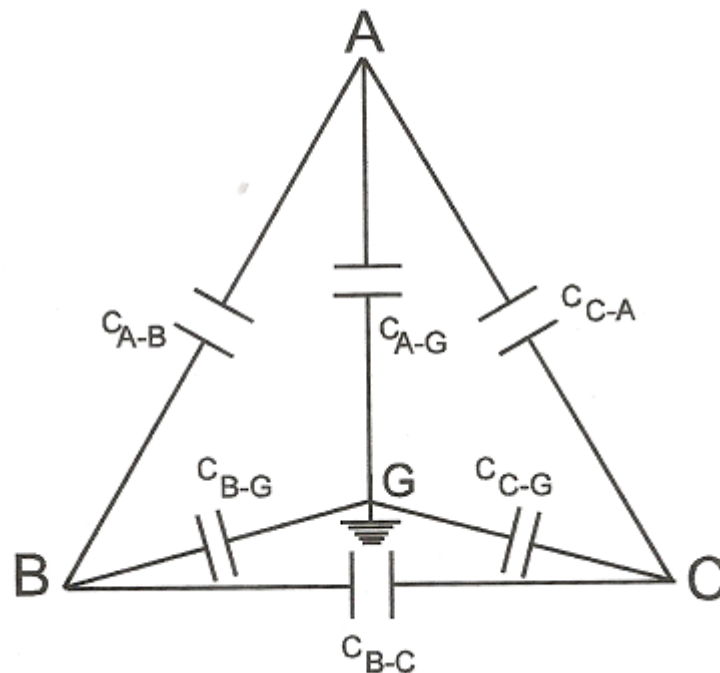

FIGURE 7-2 INSULATION SYSTEM OF A SIMPLE MACHINE

7.4.1 PREPARATION FOR TEST

MAKE CERTAIN THAT THE APPARATUS UNDER TEST AND THE ACTS-12K ARE DE-ENERGIZED BEFORE PROCEEDING WITH THE PREPARATION.

1. Clean the apparatus in the normal manner.
2. Remove risers and/ or all bus-bars and cables from all bushings.
3. Leave working grounds attached to the risers and/ or bus-bars and cables.
4. The porcelain surface of bushings should be clean and dry. Remove any dirt or oil with clean, dry rags.
5. Measure and record on the field sheet, the environmental conditions on test sheet.
6. Record the nameplate data of the machine on the field test sheet, including the factory capacitance and power factor test data (if any).

7.4.2 LEAD CONNECTIONS

The operator who makes these connections should use the Foot Switch Interlock provided to ensure no high voltage can be energized while connections are being made.

1. Set up ACTS-12K as outlined in section 2.5 of the Operating and Instruction manual.
2. Interconnect the ACTS-12K protective ground terminals. Connect ACTS-12K Ground lead to a solid ground on the transformer under test. Ensure that any paint or oxide is removed, as this may cause erroneous readings.
3. Connect the ACTS-12K High Voltage lead to the phase A of the machine under test.
4. The ACTS-12K CxL Yellow lead to the phase B of the machine under test.
5. The ACTS-12K CxL Blue lead to the phase C of the machine under test.

7.4.3 CONDUCTING THE TEST

The following is a step-by-step procedure for conducting a test on a specimen.

1. Prior to energising the Test Set, check entire circuit to make sure that all connections have been properly made and Test Set has been properly grounded.

Insure that specimen is de-energised and safe before making connections.

2. Keep POWER ON Switch at OFF position and set Voltage Control to zero.
3. Insert a shorting plug into "INTERLOCK" terminal and a Foot switch cable plug to the FOOT SWITCH terminal.
4. Connect Power supply to a suitable source of power.
5. Energise Test Set by switching on the POWER ON Switch. The red AC ON lamp should now be illuminated and the Bridge should display the following:

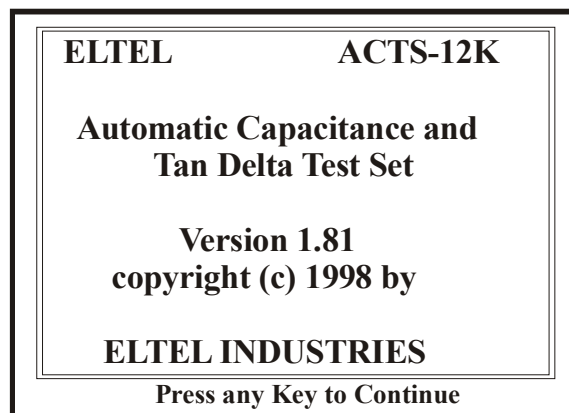

6. If Open Ground LED comes ON in the Power source, it indicates that the ground circuit in the power cable is open, or that there is a high resistance ground between the ground cable and power cable ground. The Test Set cannot be energised with high voltage with an open ground. Connect Proper ground to the Test set so that the Open Ground LED does not come ON.

7. Press any key to continue on the Bridge. Then the following display will appear.

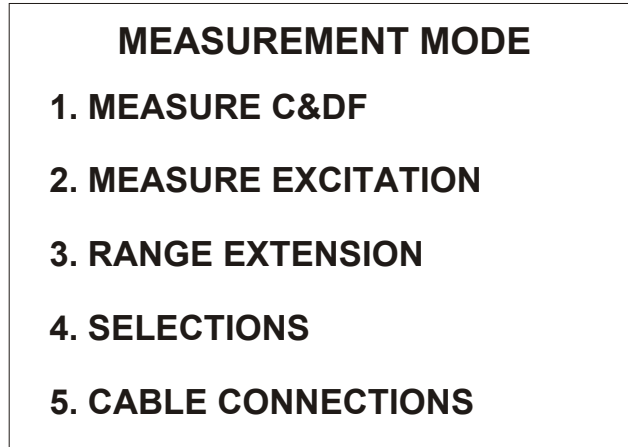

8. Press '1' to make Measurement of the Test specimen, then the following display should appear.

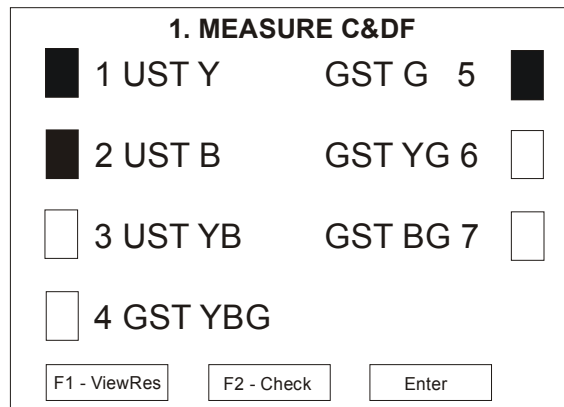

9. Although the minimum measurements are tests #1 and #5, it is recommended to include also #2, which duplicates readings. By conducting tests 1 and 7 on all three phases, it is possible to double-check every one of the readings.

Select 1 **UST Y**, 2 **UST B**, 5 **GST G** by depressing the corresponding number keys

Where: **UST Y** is the measurement from phase A to phase B, with phase C guarded.

UST B is the measurement from phase A to phase C, with phase B guarded.

GST G is the measurement from phase A to ground, with phases B and C guarded.

10. Make sure that the area is clear. Close the Foot-Switch. Set Voltage Control to 'Zero', then depress ON Output Voltage button. The two red lamps at the top of the panel should now be illuminated. If these lamps do not come on, check to see if the Voltage Control is turned down to "0" and check if OFF Switch is re-set.

CAUTION!: THE HIGH VOLTAGE POWER SUPPLY IS NOW ON.

11. Press enter on the bridge to get the following display.

1 MEASURE C&DF	
Voltage	: V
Current	: mA
Enter to Continue	

12. Advance Voltage Control to obtain desired test voltage.

Do NOT exceed the rated voltage of the apparatus under test as this may cause some damage.

NOTE: Initially make a low voltage measurement, (like 2KV for 10KV final measurement) for the safety of the Specimen as well as the instrument.

13. When the test voltage is at the desired level, press Enter to commence measurements.
14. The ACTS-12K will now proceed to perform the measurements and will display important portions of the measurement process, as they occur to give the operator an indication of what is happening.

15. When the measurements are complete, the ACTS-12K will alert the operator via an audible alert signal, followed by a display similar to the following:

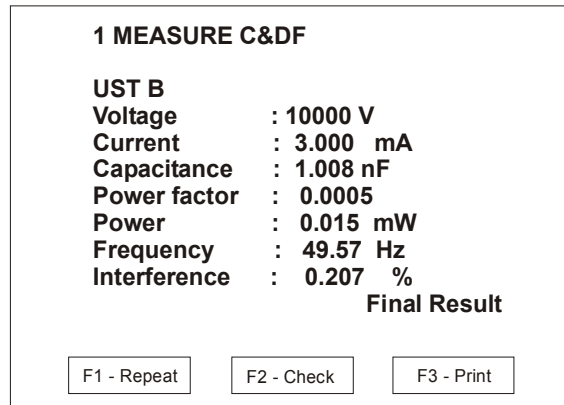

Set Voltage Control to 'Zero', then depress HV OFF Switch, to turn off the test voltage. Release the Foot Switch interlock.

The test results can be viewed by using the up & down arrow keys or printed by utilising the F3-Print function on the menu.

16. Connect the ACTS-12K High Voltage lead to the phase B of the machine under test.
17. The ACTS-12K CxL Yellow lead to the phase C of the machine under test.
18. The ACTS-12K CxL Blue lead to the phase A of the machine under test.
19. Select the Normal measurement from the Measurement mode menu.
20. Select 1 **UST Y**, 5 **GST G** and 6 **GST YG** tests.

Where:

UST Y is the measurement from phase B to phase C, with phase A guarded.

UST B is the measurement from phase B to phase A, with phase C guarded.

GST G is the measurement from phase B to ground, with phases A and C guarded.

21. Repeat steps 10 through 15.
22. Connect the ACTS-12K High Voltage lead to the phase C of the machine under test.

- 23.** The ACTS-12K CxL Yellow lead to the phase A of the machine under test.
- 24.** The ACTS-12K CxL Blue lead to the phase B of the machine under test.
- 25.** Select the Normal measurement from the Measurement mode menu.
- 26.** Select 1 UST Y, 2 UST B, 5 GST G by depressing the corresponding number keys.

Where:

UST Y is the measurement from phase C to phase A, with phase B guarded.

UST B is the measurement from phase C to phase B, with phase A guarded.

GST G is the measurement from phase C to ground, with phases A and B guarded.

- 27.** Repeat steps 10 through 15.

7.5 INSULATION TESTING OF MACHINES WITH PARALLEL WINDINGS

In some instances the machine may have two parallel windings on each phase. With all of these disconnected from the star point, one will obtain six windings to test. The diagram of capacitances to be measured is shown in FIGURE 7-3. Each winding should be tested with respect to ground and with respect to other five windings. This procedure and the number of readings is quite extensive and involved.

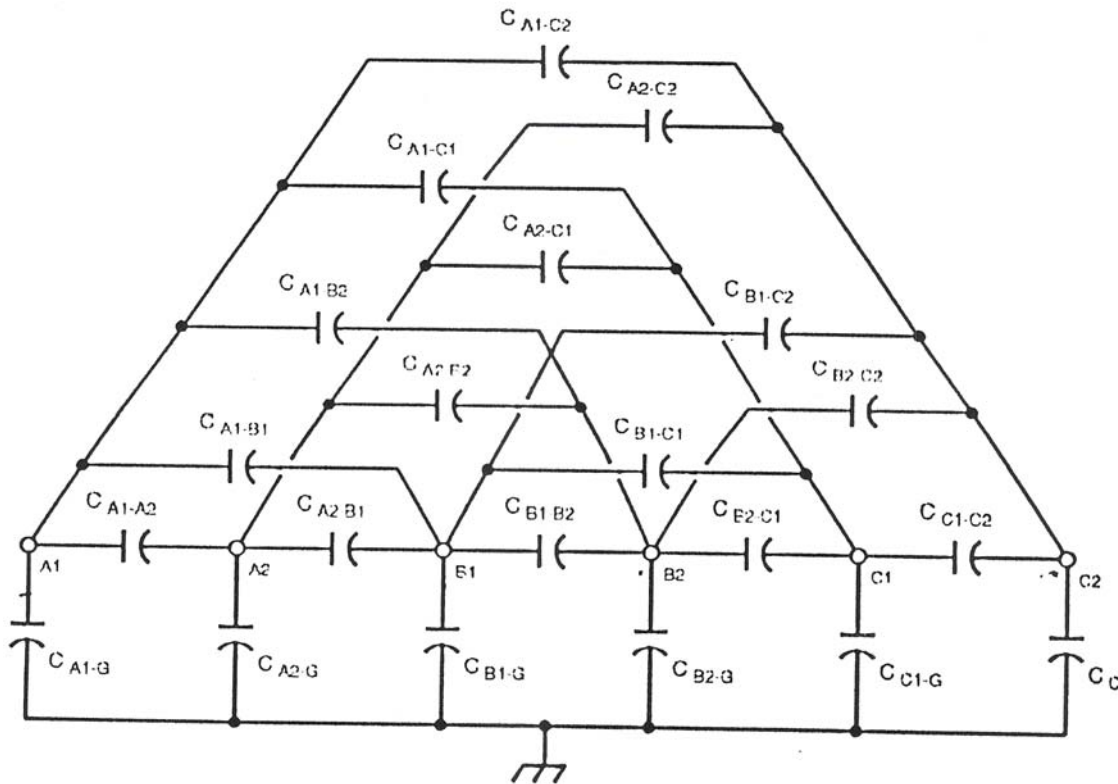

FIGURE 7-3 INSULATION OF A MACHINE WITH PARALLEL WINDINGS

7.5.1 PREPERATION FOR TEST

Follow the instructions outlined in section 7.4.1

7.5.2 LEAD CONNECTIONS

1. Set up ACTS-12K as outlined in section 2.5 of the Operating and Instruction manual.

2. Interconnect the ACTS-12K protective ground terminals. Connect ACTS-12K Ground lead to a solid ground on the transformer under test. Ensure that any paint or oxide is removed, as this may cause erroneous readings.
3. Connection for ACTS-12K High Voltage lead and the two measuring leads, CxL Y, CxL B, will be covered in the next section.

7.5.3 CONDUCTING THE TEST

Follow the operating instructions as outlined in section 7.4.3.

The table below lists the connections that have to be made and readings that are to be obtained.

CAPACITANCE	YELLOW LEAD	BLUE LEAD	TEST NUMBER
-------------	-------------	-----------	-------------

Connect HIGH VOLTAGE to A1

1. A1-G	A2	B1,B2,C1,C2	5 GST G
2. A1-A2	A2	B1,B2,C1,C2	1 UST Y
3. A1-B1	B1	B2,C1,C2,A2	1 UST Y
4. A1-B2	B2	C1,C2,A2,B1	1 UST Y
5. A1-C1	C1	C2,A2,B1,B2	1 UST Y
6. A1-C2	C2	A2,B1,B2,C1	1 UST Y

Connect HIGH VOLTAGE to A2

7. A2-G	A1	B1,B2,C1,C2	5 GST G
8. A2-A1	A1	B1,B2,C1,C2	1 UST Y
9. A2-B1	B1	B2,C1,C2,A1	1 UST Y
10. A2-B2	B2	C1,C2,A1,B1	1 UST Y
11. A2-C1	C1	C2,A1,B1,B2	1 UST Y
12. A2-C2	C2	A1,B1,B2,C1	1 UST Y

Connect HIGH VOLTAGE to B1

13. B1-G	B2	C1,C2,A1,A2	5 GST G
14. B1-B2	B2	C1,C2,A1,A2	1 UST Y
15. B1-C1	C1	C2,A1,A2,B2	1 UST Y
16. B1-C2	C2	A1,A2,B2,C1	1 UST Y
17. B1-A1	A1	A2,B2,C1,C2	1 UST Y
18. B1-A2	A2	B2,C1,C2,A1	1 UST Y

Connect HIGH VOLTAGE to B2

19. B2-G	B2	C1,C2,A1,A2	5 GST G
20. B2-B2	B2	C1,C2,A1,A2	1 UST Y
21. B2-C1	C1	C2,A1,A2,B1	1 UST Y
22. B2-C2	C2	A1,A2,B1,C1	1 UST Y
23. B2-A1	A1	A2,B1,C1,C2	1 UST Y
24. B2-A2	A2	B1,C1,C2,A1	1 UST Y

Connect HIGH VOLTAGE to C1

25. C1-G	C1	A1,A2,B1,B2	5 GST G
26. C1-C2	C1	A1,A2,B1,B2	1 UST Y
27. C1-A1	A1	A2,B1,B2,C2	1 UST Y
28. C1-A2	A2	Á1,Á2,C2,A1	1 UST Y
29. C1-B1	B1	B2,C2,A1,A2	1 UST Y
30. C1-B2	B2	C2,A1,A2,B1	1 UST Y

Connect HIGH VOLTAGE to C2

31. C2-G	C1	A1,A2,B1,B2	5 GST G
32. C2-C1	C1	A1,A2,B1,B2	1 UST Y
33. C2-A1	A1	A2,B1,B2,C1	1 UST Y
34. C2-A2	A2	Á1,Á2,C1,A1	1 UST Y
35. C2-B1	B1	B2,C1,A1,A2	1 UST Y
36. C2-B2	B2	C1,A1,A2,B1	1 UST Y

It should be pointed out that the above 36 readings provide duplication of the phase-to-phase capacitance measurements. This is a convenient method of checking the work and test results.

7.6 TEMPERATURE CORRECTIONS

As typical tests are conducted indoors, the insulation temperature will be in the range of 20 to 30°C, and temperature correction may not be required. In the cases where temperature correction is required, it is recommended that the manufacturer of the machinery be contacted.

7.7 INTERPRETATION OF RESULTS

There are three determinations that will help assess the condition of the machine insulation. These are :

1. Power factor at low voltage
2. Power factor TIP-UP
3. Comparison between phases

To help in the interpretation of the test results, it is convenient to prepare plots of the dissipation factor of the insulation against the test voltage for the different portions of the insulation. It is most convenient to have data available from factory tests or from previous measurements in order to make a proper judgement.

7.7.1 POWER FACTOR AT LOW VOLTAGE

The Power factor of the insulation at low voltage is an indication of the condition of insulating material. Thus if the dissipation factor at low voltage has increased, it indicates the possibility of moisture or other contamination of the insulation.

The moisture content of insulation can typically be confirmed by a dc insulation test. Moist insulation will show unacceptably low insulation resistance.

The power factor of older insulating materials is very susceptible to absorption and penetration by moisture. Modern insulating materials are typically impervious to moisture and do not exhibit the same effect.

It should be remembered that it is the trend of the increasing dissipation factor of the machine insulation that should initiate corrective action rather than the absolute value of the dissipation factor.

7.7.2 POWER FACTOR TIP-UP

Power factor tip-up is a measure of the insulation at higher voltage. Power factor tip-up indicates non-linearities in the insulation. Tip-up is caused by partial discharge activity within the insulation and is undesirable as it causes further degradation of the insulation.

The acceptable amount of tip up depends on the type of insulation used. Older types of insulation systems, such as "asphalt-mica" are quite tolerant of partial discharge and will perform adequately for a long period of time even if they exhibit substantial tip-up. They exhibit substantial tip-up when new.

Excessive tip-up on older machines may indicate a need for rewinding the stator.

New types of insulation, using polyester and epoxy type resins, do not tolerate partial discharge as well. Because the insulation is typically very hard it suffers from damage due to vibration and stresses caused by the differential expansion and contraction of component as the machine heats up and down due to the loading cycles.

Excessive tip-up on machines with modern insulation may indicate a need to re-wedge the windings, reapplication of semiconductor voltage stress grading areas, or other problems.

With age and deterioration, the tip-up will increase or the same tip-up will be exhibited at a lower voltage.

7.7.3 COMPARISON BETWEEN PHASES

It should be remembered that each machine will have atleast six similar components of insulation. These components will show a gradual increase in dissipation factor and tip-up with age if they are deteriorating similarly.

The similarity between the readings on a machine can be used to draw certain conclusions even if prior history of the machine insulation is not available. Thus, if any one of the components shows a marked difference from the others, this should trigger and investigation and perhaps additional test.

The capacitance and the dissipation factor of the phase to ground insulation should provide the same, if not identical readings. The same applies to the three phase to phase readings.

Even though the phase to ground insulation will exhibit a much different capacitance then the phase-to-phase insulation, their dissipation factor should be basically the same.

Chapter 8.

EXCITATION CURRENT TESTING OF TRANSFORMERS

8. EXCITATION CURRENT TESTING OF TRANSFORMERS

Excitation current testing provides information about possible core faults and/ or winding conditions. The ACTS-12K in addition to indicating the voltage and current also indicates dissipation factor. This indication is a very useful tool in determining the condition of the core and the windings (both high and low). When the core starts deteriorate, it's losses increase and hence D.F increases. The same is true with shorted or partially shorted turns. This testing, together with turns ratio and winding resistance is an effective method in determining core and winding condition.

All tests are conducted on high voltage windings as this reduces risk of stepping up voltages beyond transformer rating. Defects in low voltage will be picked up with this same test. When a low voltage winding is specifically suspected of a fault, an excitation test can be performed on the low voltage windings provided safety precautions are taken.

8.1 PREPARATION FOR TEST

MAKE CERTAIN THAT THE APPARATUS UNDER TEST AND THE ACTS-12K ARE DE-ENERGIZED BEFORE PROCEEDING WITH THE PREPARATION.

TESTS SHOULD NOT BE CARRIED OUT WHEN RAIN IS FALLING OR WHEN THERE IS CONDENSATION ON THE PORCELAIN.

1. Clean the transformer in the normal manner.
2. Remove risers and/ or all bus-bars and cables from all bushings.
3. Transformers with no-load tap changers should be set to the nominal or normally used tap position.
4. Test the transformers with on-load tap changers at neutral and one position in raise direction and one position in lower direction.

NOTE: If a problem exists in any of the tap position (including neutral), the excitation current will increase for all tests conducted in this step. In the 3 tests recommended in this step, each should show increased current readings with faults in high side or low side of the transformer.

5. All testing is done in the UST mode. Typically, this has the low voltage yellow lead as the return current path. All current through ground is guarded.
6. On transformers with low voltage secondaries, is good practice to ground one end of the secondary as this reduces possibility of high voltage coupling and hence damage to secondary.

8.2 LEAD CONNECTIONS

1. Set up ACTS-12K as outlined in section 2.5 of the Operating and Instruction manual.
2. Interconnect the ACTS-12K protective ground terminals. Connect ACTS-12K Ground lead to a solid ground on the transformer under test. Ensure that any paint or oxide is removed, as this may cause erroneous readings.
3. The high voltage lead, CxH red lead and CxL Blue lead are connected to the apparatus under test according to the type of the transformer. Refer to FIGURES 8-1. To 8-3

8.3 CONDUCTING THE TEST

The following is a step-by-step procedure for conducting a test on a specimen.

1. Prior to energising the Test Set, check entire circuit to make sure that all connections have been properly made and Test Set has been properly grounded.
Ensure that specimen is de-energised and safe before making connections.
2. Keep POWER ON Switch at OFF position and set Voltage Control to zero.
3. Insert a shorting plug into "INTERLOCK" terminal and a Foot switch cable plug to the FOOT SWITCH terminal.
4. Connect Power supply to a suitable source of power.

5. Energise Test Set by switching on the POWER ON Switch. The red AC ON lamp should now be illuminated and the Bridge should display the following:

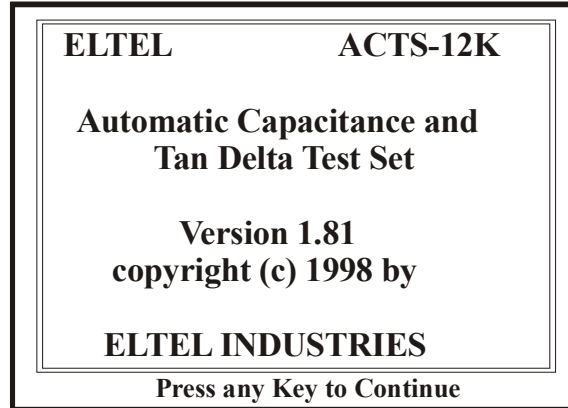

Press any key to go to Measurement mode, then the following screen will appear.

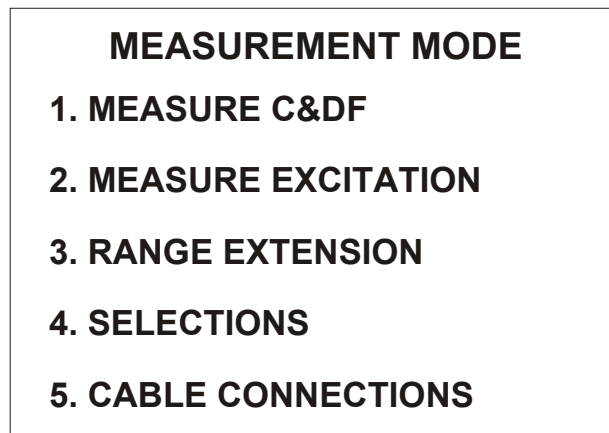

Press key '2' to go to measure excitation, then the following screen will appear

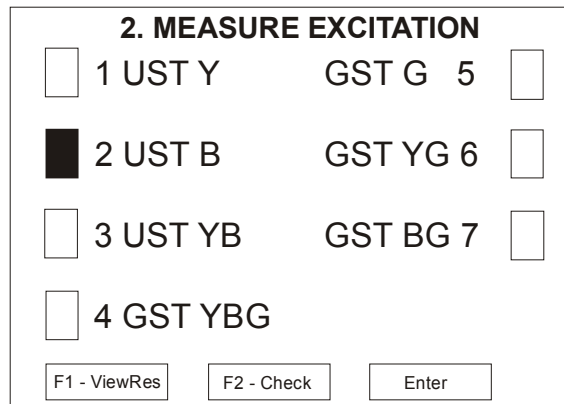

Unlike C&DF measurement, this is a continuous measurement only one measurement can be selected.

Insert a shorting plug into "INTERLOCK" terminal and a foot switch cable plug to the "FOOT SWITCH" terminal.

Set voltage control to "0".

Depress the foot switch.

Energise set by closing "POWER ON" switch.

Depress the HV ON push button.

Advance VOLTAGE CONTROL obtain desired test voltage.

Read the value of transformer excitation current on the test voltage.

Note : If Breaker trips when advancing VOLTAGE CONTROL in step 6 above the output capabilities of the power supply have been exceeded and it will be necessary to measure the transformer excitation current at a lower test voltage.

When the test has been completed. The following screen will be displayed and inductance of the transformer will be displayed on the screen. Now gradually reduce the test voltage to zero, release the foot switch or depress "HV OFF" push button and then switch off the Test set.

MEASURE EXCITATION	
Voltage	:
Current	:
Inductance	:
Power factor	:
Power	:
Frequency	:
Interference	:

WARNING : Ground the transformer terminals with a safety ground (USE A "HOT STICK"). Always disconnect test cables from the test specimen before attempting to disconnect them at the test set.

9

Chapter 9. MAINTENANCE AND TROUBLESHOOTING

9.0 MAINTENANCE AND TROUBLESHOOTING

General notes for servicing of model ACTS-12K

Instrument not switching on

- Check the power supply 230V ac/110V AC. (between line and neutral)
- Check for the continuity of the power in cable.
- Check the functioning of the 10 A MCB in the front panel of the power source.
- Check for the 230V /110Vat the primary terminals of the LV transformer inside the power source (EI12slv) and also check for 18V ac at the secondary side of the same transformer.

Bridge not switching on

- Check the power inter connecting cable (from power source to bridge).
- Check 230V ac at the primary side of transformer inside the bridge (EL19ISO) and also the secondary side voltage.

Open ground indication continuously on

- Check for the power supply earthing.
 - Between line and neutral 230V ac
 - Between line and ground 230Vac
 - Between neutral and ground <5V ac
- Check whether the ground cable is connected from the instrument to main earthing.
- If the above two conditions are satisfied and problem still persists the adjust the trim pot P6 slowly towards right in the control PCB (2k18c01) inside the power source unit with all the cables connected.

Open interlock indication continuously on

- Check the 3 pin shorted interlock connector is connected properly at the back panel of the power source.
- Check the switching of the foot switch using multi meter (in continuity mode with probes in pin 1& pin2).
- Check the mains power supply (230V AC) it should be within 207 & 253 V AC.

Over voltage indication.

- This indication comes if the out put voltage is more than 12kV, if reset is pressed then this indication will be off.
- Check the high voltage cable for the continuity. Sometimes because of the fault observed in the high voltage cable this might happen.

Short circuit indication.

- This indication comes if there is a short between high voltage cable and low voltage cable or between high voltage cable and ground, if reset is pressed then this indication will be off.

Some of the common problems observed in the site.**High voltage not raising.**

- Make sure that all the above mentioned lamps/indications are off & HV off switch in the front panel of the power source is in released condition.
- Check for the zero start functioning using multimeter (in continuity mode) by keeping the probes in J11connector (black & brown wires) in control PCB (2k18c01) of power source unit.
- Check the TEST POLARITY cable for one to one connection.
- Check the selector switch at the back panel of the power source just below the HV connector.
- Check also the Cn cable for one to one connection.

Bridge switching on but display blank.

- Open the top cover of the bridge unit.
- Check the input (ac voltage) to the S.M.P.S
- Check the dc voltage at the output of the S.M.P.S
- Check for +5Vdc (red wire), +12V dc (orange wire) & -12Vdc (yellow wire) with respect to ground (black wire).

Instrument tripping at some voltages.

- Check whether HV cable is properly inserted inside the HV connector in the instrument or not.
- Check whether Cn cable is properly inserted into its corresponding connectors.
- Check the connections at the specimen end also there should not be any loose connections and also sufficient gap between HV cable ground and LV cable.

Wrong readings of specimens.

- Check for any possible loose contacts of cables at the specimen end..
- Check the dc voltages as mentioned above.

Printer not responding.

- Ensure that instrument is connected to printer port firmly.
- Ensure that printer is switched on.
- If still printing is not happening then test with other printer cable.

Continuous beep sound.

- Switch on the instrument check whether beep sound is coming and instrument is hanging.
- Switch off the instrument, open the top cover of the bridge disconnect the keyboard connector from the digital board (middle board from the front side), switch on the instrument check for the previous step, if that is not happening then front panel of the instrument is having problem.

RS-232 port not communicating.

- Ensure RS-232 cable is connected firmly to the computer as well as to the instrument end.
- Check for the comm. Port settings.(eg:com1,com2,com3.....).
- Ensure that bridge is switched on.
- If still communication is not happening then test with other RS-232 cable.

Above mentioned procedure is to have preliminary checks of the instrument at the site, but if still problem persists then please contact the following addresses.

Office :

ELTEL Industries
 311, Embassy Centre, Crescent Road,
 Bangalore - 560 001.
 INDIA
 Tel : 91-80-22255467, 22205686,
 22284298, 22284253
 Fax : 91-08-22252733
 E-mail : marketing@eltelindustries.com
 Web : www.eltelindustries.com

Factory :

ELTEL Industries
 Plot # 39, KIADB Industrial Area,
 Veerapura, Doddaballapur,
 Bangalore - 561 203.
 INDIA
 Tel : 91-80-27630350, 27630366,
 27630367, 27630368
 Fax : 91-08-27630351
 E-mail : eltel@vsnl.net
 Web : www.eltelindustries.com